

ARCOptix

Variable Phase Retarder

ARCOptix S.A
Fbg de la gare 5a
2000 Neuchâtel
Switzerland
Mail: info@arcoptix.com

Optical phase shift generated by Liquid Crystal planar cell

Optical retardation is often obtained with piezo-electric mirrors. However this option is not ideal if robust and compact design is necessary. LC variable phase shifter (VPR) offer an interesting alternative especially when working with polarized light (which is often the case when working with lasers). The Arcoptix VPR is a transmissive element causing minimal losses and can be simply placed within the optical path of our system. The more, the optical retardation (or phase shift) of the LC phase shifter is electrically tuneable with a simple laboratory alternative power supply or function generator. It can also be used as optical valve (for a narrow wavelength range) or as polarization State controller.

The liquid crystal VPR (or phase retarder) can be compared to a tuneable waveplate. By addressing it with the right voltage, the LC VPR is able to provide any phase shift from zero to several times the light wavelength. They can be used throughout the visible and the near infrared region (350nm to 1800 nm) without losses higher than 20%. Thanks to the use of thick substrate and a special liquid crystal bend we are capable to offer robust equipment with minimal wavefront distortion (lower than $\lambda/4$).

Principle of the liquid crystal phase retarder

The Arcoptix VPR are manufactured with standard liquid crystal technology. As depicted in figure bellow, they are principally made of a liquid crystal layer sandwiched between two flat glass plates coated with a transparent electrode (ITO) and an alignment layer. The two glass plates are precisely spaced apart with a glass fibers at the edges. The cavity formed by these plates is filled with a special blend of liquid crystals optimized for high birefringence, small temperature dependence and high stability. The cell is hermetically sealed with glue. The alignment layer is a gently rubbed polyimide layer necessary for the alignment of the LC molecules. The electric field that can be induced by applying a voltage on the transparent ITO electrodes (0-7V) modifies the alignment of the LC molecules and by the same way the apparent retardance of the cell. Figure (a) shows the alignment of the LC molecules when no voltage is applied. In this case the molecules are aligned along the glass plates and the retardance (along

the optical axis) is maximum. Figure (c) shows the other extreme case where a “high” voltage (7V) is applied and the electric field forces the LC molecules to align perpendicularly to the glass plates (parallel to the electric field). Figure (b) shows an intermediate state where we apply a small voltage of about 3V. In this case the molecules have an oblique orientation and the apparent retardation is somewhere in between the maximum retardation (several times the wavelength) and the minimum retardation (almost zero). Notice that a very thin LC layer near the substrate surface will stay with a certain tilt angle which prevent having a perfect zero phase shift without additional compensation plate.

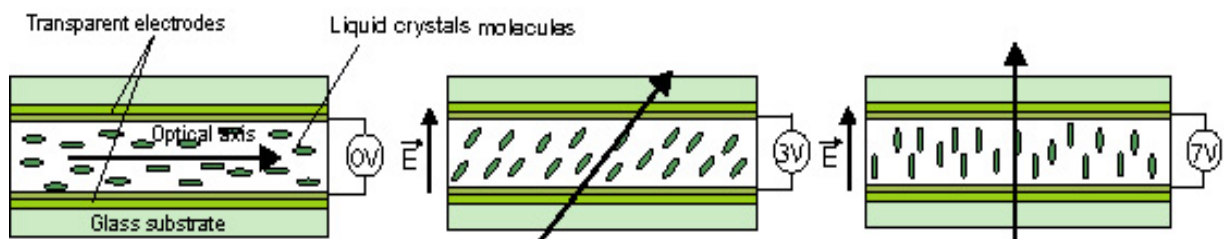

Orientation of the LC molecules (or optical axis) in the phase retarder in function of the applied tension. For 0 V (a), 3 V (b), 7 V (c).

Retarder type selection

When selecting a phase retarder some key features must be considered such as:

- Aperture size
- Position of the phase shifter (in an imaging plane or not?)
- Size
- Switching time
- Wavelength
- Damage threshold
- Transmission
- Phase distortions (eventually compensated by lenses)
- Beam deviation
- Maximum phase retardance
- Retardation stability
- Optical axis orientation
- Zero phase shift
- Precision

In functions of your needs you can select essentially between three categories of products:

Retarder Type	Specificities	Applications	Price
Industrial grade	<ul style="list-style-type: none"> •Spacer (few microns) over the aperture •Large aperture •Thin substrates •Phase distortions (spherical) • low beam deviation 	<ul style="list-style-type: none"> •Polarization manag. •Polarization vision 	**
Scientific grade	<ul style="list-style-type: none"> •Low phase distortions •No beam deviation •No spacers over the aperture •Aperture 10 or 20 mm •Thick substrates •AR Coating 	<ul style="list-style-type: none"> •Interferometry •Metrology •Use in an imaging plane 	***
Custom	<ul style="list-style-type: none"> •Larger apertures. •High switching speeds. •Large quantities/low price. •Zero phase shift 	<ul style="list-style-type: none"> •Custom adapted cells for industrial applications •Specific scientific applications 	* / ****

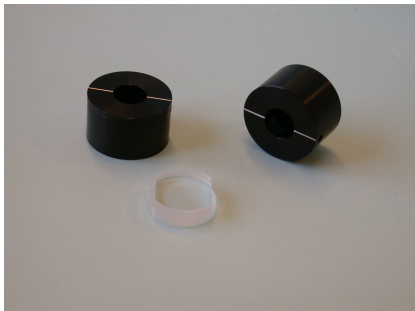

Scientific grade cell 10 mm aperture



Scientific grade cell 20mm aperture



Industrial grade cell 23mm aperture without housing

Specifications

The specs (for industrial and scientific grade cells) below are given for a linear input polarization parallel to the optical axis of the liquid crystal layer.

Phase shift range	50-1200 nm (max. 3000nm)
wavelength range	350-1800 nm
Active area	scientific grade: 10 mm or 20mm (diam.) Industrial grade: 23 mm (square)
Transmission	About 85% (VIS)
Retarder material	Nematic Liquid-Crystal typically $\Delta n=0.14$, but depends on wanted retardance
Substrates	Glass
wavefront distortion	scientific grade: < $\lambda/4$ (over 10 mm) Industrial grade: < 2 λ (over 23 mm)
temperature range	15°-35°
Retardance temperature dependency	About 0.5%/°C (wavelength dependent)
Phase shift adjustment precision	10nm
Rise and fall time	1ms rise and 150ms fall
Phase shift stability (with arcoptix LC driver and at thermal equilibrium)	Better than 10 nm.
AR Coating (scientific grade only)	Broadband for VIS.
Safe operating limit	500 W/cm ² CW 1 J/cm ² , 10 ns, above 500nm 60mJ/cm ² , 40fs, 800nm
Total size (with housing)	Scientific grade: 25mm diameter, 16mm long Industrial grade: 31mmx25mmx2.2mm (without housing).

Transmission

Total transmission of the phase shifter (including losses due to reflections) is given by the graph below.

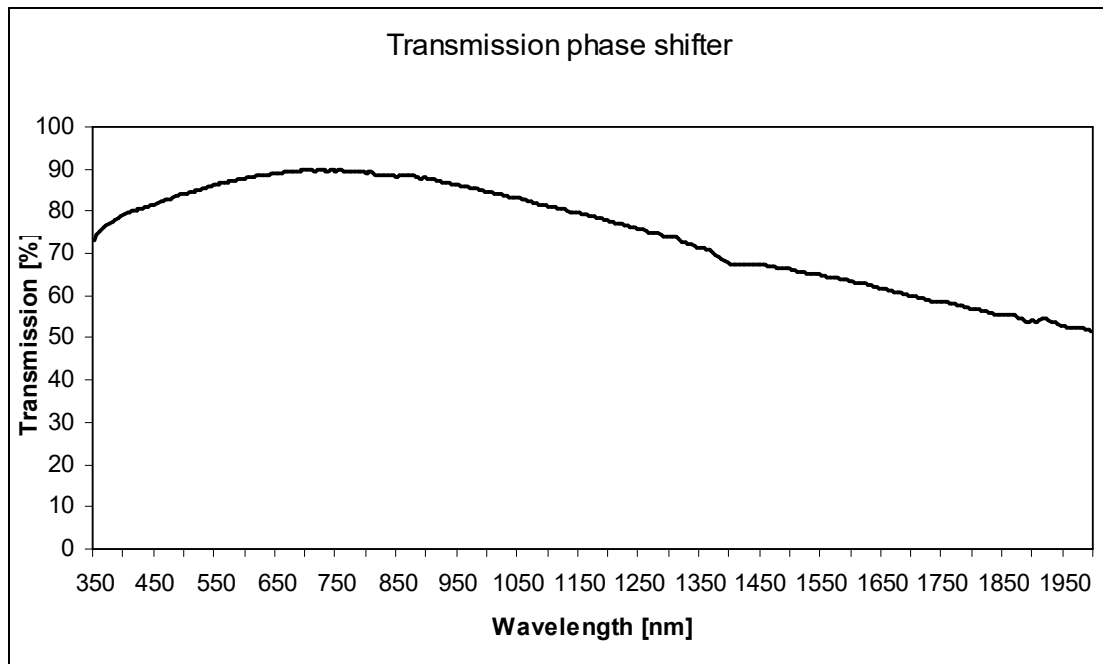

Phase retardance calibration

There is a non-linear relation between the phase retardance and the applied voltage. This calibration curve which depends of the wavelength and the temperature of the LC cell valid for room temperature indicates the correspondence between the phase retardance and the applied bias. The graph in annex shows such curve for a standard phase retarder at room temperature and 633nm.

Damage threshold

We must distinguish here between pulsed and CW lasers.

Pulsed lasers induce a different type of damage to the optic than CW lasers. Pulsed lasers often do not heat the optic enough to damage it; instead, pulsed lasers produce strong electric fields capable of inducing dielectric breakdown in the material. Unfortunately, it is difficult to give an exact damage threshold for every laser on the market. There is a great variability of pulse duration, wavelength, repetition rates and beam diameter. Globally we can say that the LC cell withstand most of the lasers on the market. Of course, it does not withstand for example

some powerful machining lasers (but these cases are mostly obvious to the customer). The below values are indicative damage thresholds for different types of lasers. Notice that below 450nm ITO coating is absorbing more and threshold is much lower.

Continuous Laser CW above 450nm	500 W/cm ² CW
Continuous Laser CW below 450nm	50 W/cm ² CW
Pulsed lasers ns (above 500nm)	1 J/cm ² 10 ns, visible
Pulsed laser femto second (above 500nm)	60mJ/cm ² , 40fs, 800nm

Switching time

Switching time of parallel aligned liquid crystal is relatively slow compared to twisted nematic liquid crystal (as the are used in LC screens for example). This is due the eleastic constant that are different for different LC alignment configurations.

For the LC variable retarder we use a parallel alignment. We must consider to switching time the rise time (where we apply an electric field) and the switch off (where we switch off the electric field). The rise time is much faster (around 1 ms) than the fall time (around 100ms-200ms). This switching fall time depends of many parameters like cell thickness (or total retardance), used liquid crystal, wanted retardance difference and temperature. Below table gives indicative values for a standard liquid crystal with total retardance of 1200 nm.

Rise Time room temp	~ 1ms
Fall time room temp. 1200nm retardance cell (10-90%)	~ 150ms
Fall time 45°C. 1200nm retardance cell (10-90%)	~ 80ms
Fall time room temp. 2500nm retardance cell (10-90%)	~ 250ms

Electrical driving:

The VPR needs to be connected to an alternative (AC) power supply producing a square wave signal with change of polarity (oscillating between positive and negative bias). To drive the VPR there are essentially two options:

- 1) Use the Arcoptix digital LC Driver that has four independent outputs that are computer controlled via USB and optimized for liquid crystal device driving. It generates a square signal of 1.6 KHz with variable amplitude between 0V and 9V. The LC driver produces a highly stable signal with a precision of 1mV. An external trigger input can be provided on demand.
- 2) Use a standard labor generator with square wave signal. The should be somewhere around 0.1-1 kHz and the amplitude should be variable between 0 and 10V (almost no current).

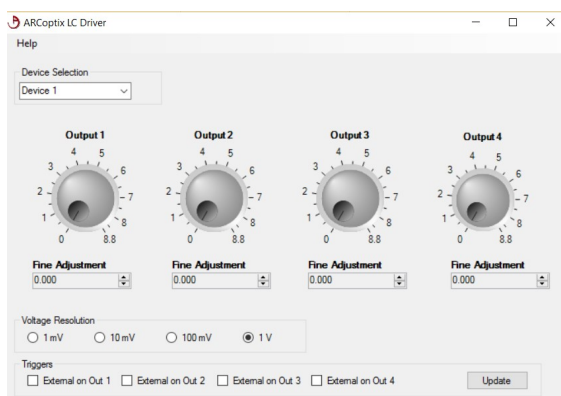

LC Driver with four independent outputs that are computer controlled via USB.

LC cells are usually driven with AC square-wave voltages of between ± 1.0 and ± 10 volt whereby the polarity is rapidly switched at speeds of up to 1KHz (the frequency is not very important, typically more than 10Hz) in order to prevent impurity ion migration from occurring. A priori, it may be expected that activation of the LC cell with AC voltage might cause the molecules to rotate. However in practice interactions between the LC molecules themselves hinder this and if the polarity change is rapid enough (which is generally the case for a square wave) the molecules “do not have enough time to react”. Polarity reversal (when it is performed quickly) of the driving electronics will therefore have no effect upon the alignment of the molecules and the performance of the device is only dependent upon

the root-mean-squared (rms) voltage and not on the polarity of the external field.

Notice that the phase shift stays constant when applying a square shaped function because of the slow reaction time of the LC molecules. Only slowly varying applied voltages below 50HZ may change the phase shift.

Optical setup

The LC variable phase shifter can only be used when working with polarized light. Totally unpolarized light will not be affected by the phase shifter.

There are mainly two ways to use the phase shifter:

1) The incoming light is polarized parallel with respect to the optical axis of the phase shifter. In this case the beam maintains its polarization and the beam experiences a certain phase retardance inversely proportional to the applied bias on the variable phase shifter.

2) The incoming polarization is oriented by 45° with respect to the optical axis of the phase shifter. In this case the polarization state at the output of the phase shifter will change depending of the applied bias. When placed between two polarizers, this configuration acts as a variable attenuator (see application notes).

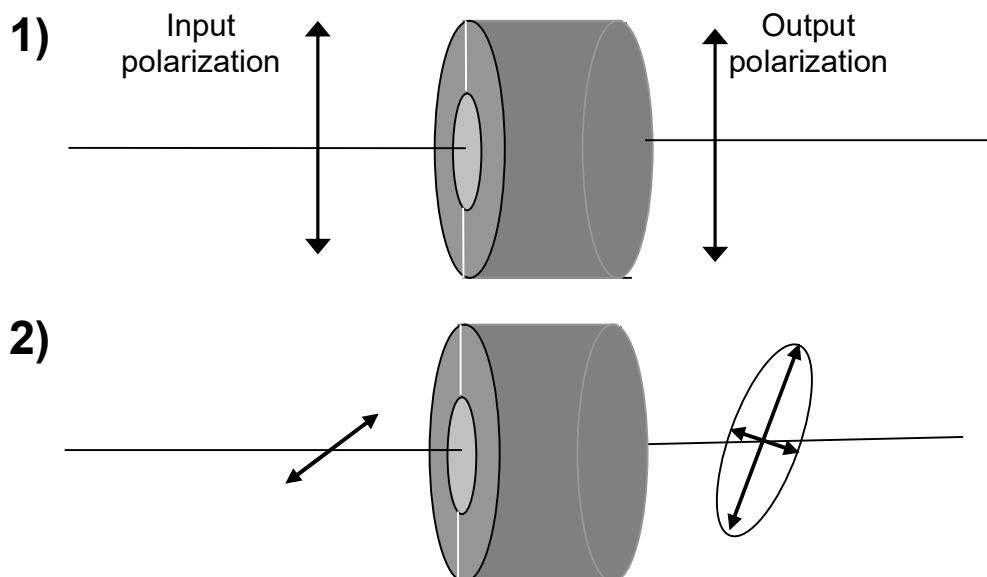

Housing:

10 mm aperture version: The Housing (scientific grade) is made of anodized aluminum. It has a diameter of 25mm and can be easily mounted into any standard optical mount. The optical axis is indicated by a stripe.

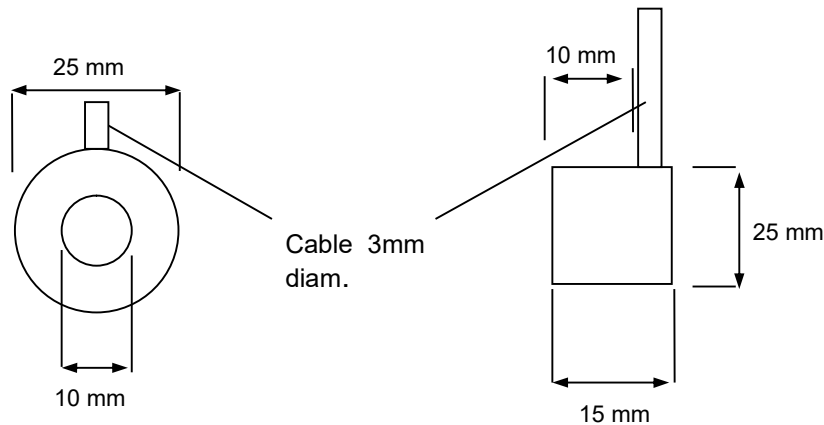

20 mm aperture version: The Housing (scientific grade) is made of anodized aluminum. It has a total diameter of 60mm and can be easily be mounted on a post via an M4 thread on the bottom side of the device. The optical axis is indicated by a stripe and can be oriented with an integrated rotation mechanism in any direction between 0° and 90°. The Device can be connected to its driver via a Lemo connector.

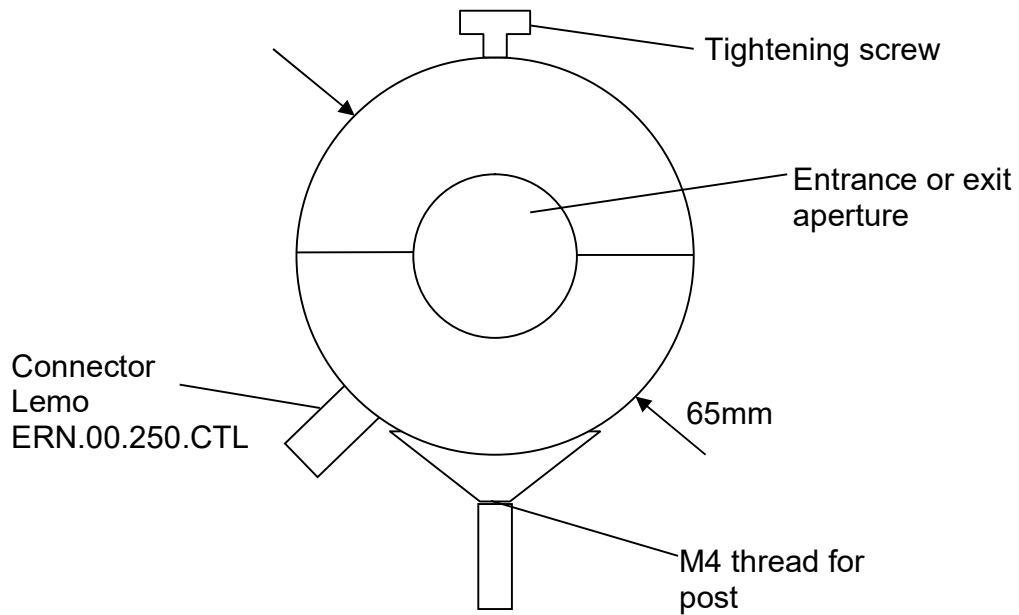

Custom Design

Design and quotes for custom specifications such as switching time, active area, twist angle, total size, housing can directly be asked by sending us an email at info@arcoptix.com.

Specifications

Listed specifications are accurate as of the publication date. Product improvements and design changes may alter product specifications without notice.

Warranty

All products in this catalog are warranted against defects in materials and workmanship for a period of one year from the date of shipment. Liability of Arcoptix is limited to the defective product value only.

Shipping

We will use our best judgement regarding shipping Method (mostly with DHL), unless a specific carrier is requested. Freight charges are paid by the receiver.

Ordering information

Quotes can be asked by
e-mail: info@arcoptix.com.

Final order should be placed by sending use a signed fax containing the ordering details.

Annex: The Retardation ($d(n_e(V)-n_e)$) between the two halves of the retarder cell measured as a function of $V_{\text{amplitude}}$ (1 kHz square wave)

and for a wavelength of 633nm (retardation may have a slight wavelength dependency).

